

Utektura coming



VOGLAUER



Die neue Kollektion Vtektura zeigt eine starke Hingabe an den alpinen Markenkern und zeichnet sich bei den Korpusmöbeln durch die Verwendung von pigmentiertem Glas aus, das an die Struktur eines Gletschers erinnert.

The new Vtektura collection shows a strong dedication to the alpine brand essence and is characterised by the use of pigmented glass, which is reminiscent of the structure of a glacier.

La nouvelle collection Vtektura témoigne d'un fort attachement à l'essence alpine de la marque et se caractérise par l'utilisation de verre pigmenté, qui rappelle la structure d'un glacier.

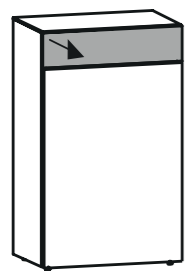

B/T/H - W/D/H - L/P/H
64/42,6/106

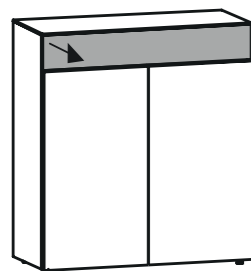

B/T/H - W/D/H - L/P/H
96/42,6/106

Klare Linien
prägen Form
und Funktion.

Pure lines characterize
form and function.

Des lignes pures
soulignent la forme
et la fonction.



Meisterstücke der Natur.

Masterpieces of nature.

Des chefs-d'œuvre de la nature.

Vorschlag 53
Wildeiche rustiko Schwarz geölt | Glas Firneis white
Rustic black oiled wild oak | Glass Firneis white
Chêne sauvage, rustique huilé noir | Verre Firneis white



Vorschlag 27
Alteiche rustiko Schwemmgrau lackiert | Glas Firneis dark
Grey rustic oak varnished | Glass Firneis dark
Chêne rustique gris laqué | Verre Firneis dark

Kleine Räume – große Ideen.

Small rooms – big ideas.

Petites pièces – grandes idées.



Gletscher-Architektur für Zuhause.

Glacier architecture for the home.

L'architecture du glacier dans la maison.

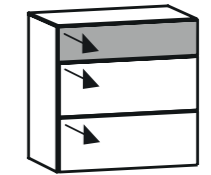

B/T/H - W/D/H - L/P/H
64/42,6/64

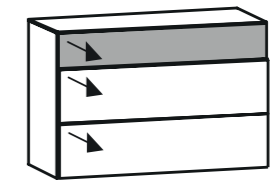

B/T/H - W/D/H - L/P/H
96/42,6/64



B/T/H - W/D/H - L/P/H
96/41,2/24

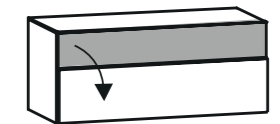

B/T/H - W/D/H - L/P/H
96/42,6/40

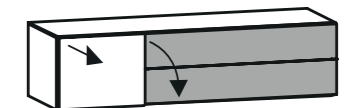

B/T/H - W/D/H - L/P/H
128/42,6/32

Qualität aus Österreich



Garderobenpaneele TDG16A
 Wildeiche rustiko Schwarz geölt | Glas Firneis white
 Rustic black oiled wild oak | Glass Firneis white
 Chêne sauvage rustique huilé noir | Verre Firneis white



Dielenschrank TDD96
 Wildeiche rustiko Schwarz geölt | Glas Firneis white
 Rustic black oiled wild oak | Glass Firneis white
 Chêne sauvage rustique huilé noir | Verre Firneis white

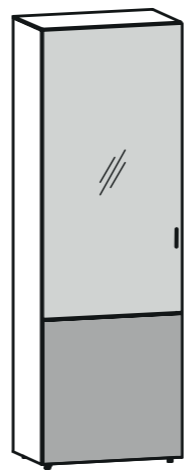

B/T/H - W/D/H - L/P/H
 64/41,2/194

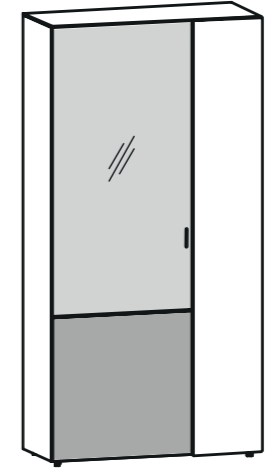

B/T/H - W/D/H - L/P/H
 96/42,6/194



Der erste Eindruck zählt.



Materialerlebnis für die Sinne.

Materials that awaken the senses.

Des matériaux qui éveillent les sens.

*First impressions matter.
La première impression compte.

Vorschlag 43
Wildeiche rustiko Schwarz geölt | Glas Firneis white
Rustic black oiled wild oak | Glass Firneis white
Chêne sauvage rustique huilé noir | Verre Firneis white



Glas - Firneis white

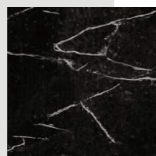

Glas - Firneis dark

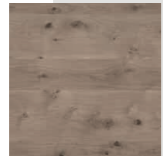

Alteiche rustiko
Schwemmgrau lackiert

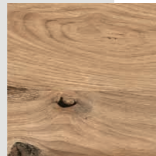

Wildeiche rustiko
Schwarz geölt



MG | grauweiß



MB | basaltgrau



CN | natur



CM | melange

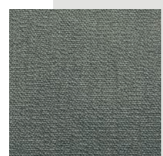

CW | warm grey



CT | timber



CS | steele

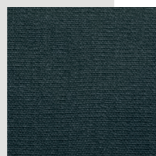

CB | black

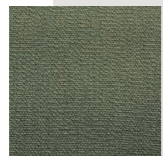

CO | olive

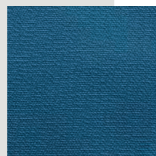

CD | dark blue

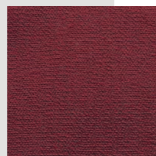

CR | royal red

Glasakzent

Glass accent
Accent verre

Sorgsam ausgesuchte Hölzer

Woods: grey rustic oak varnished & Rustic black oiled wild oak
Bois: chêne rustique gris laqué & chêne sauvage rustique huilé noir

Bezugstoff | Fabric | Tissu d'ameublement

* eingeschränkt verfügbar, siehe Typenliste (Webseite) | limited availability, see type list (website)
| disponibilité limitée, voir liste de modèles (site web)

Loden | Loden | Loden

Loden besteht aus 100 % reiner Merino-Schurwolle und ist daher ein hochwertiges Naturprodukt. Der Rohstoff Wolle ist langlebig, luftdurchlässig, hautfreundlich, elastisch, isolierend und durch seinen Fettgehalt schmutzabweisend.

Loden consists of 100% pure Merino Wool, and is therefore a high-quality natural product. Raw wool is durable, breathable, skin-friendly, elastic, insulating and dirt resistant due to its fat content.

Le loden est composé à 100 % de pure laine vierge mérinos et de ce fait un produit naturel de grande valeur. La matière première laine présente une durée de vie élevée, est perméable à l'air, agréable sur la peau, élastique, isolante et repousse la saleté grâce à sa teneur en graisse.

Curl | Curl | Curl

Textil in Naturhaptik mit höchster schmutzabweisender Eigenschaft (Patentiert Q2 Faser, 74/26 PAN/PES).

Textile in natural haptics with highest dirt-repellent property (patented Q2 fiber, 74/26 PAN/PES).

Textile au touché naturel avec propriétés hautement anti-poussière (breveté Q2 fibre, 74/26 PAN/PES).

MATERIALIEN

MATERIALS | MATÉRIAUX



LR | reinweiß



LY | ziegelrot

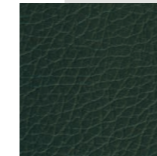

LZ | army green

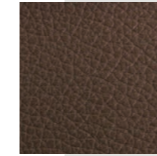

LU | caffè

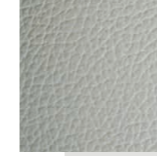

LK | kiesel



LM | stone

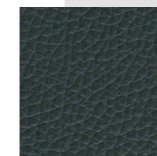

LN | anthrazit

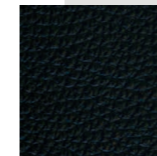

LS | schwarz

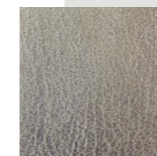

VQ | quarz

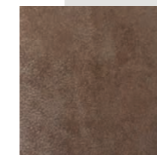

VT | terra

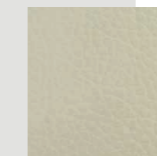

LW | sahne

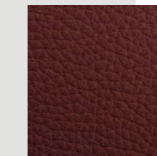

LX | burgundy



LV | cognac

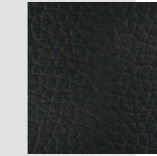

LT | testa di moro



LO | coco

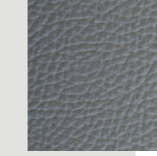

LP | cenere

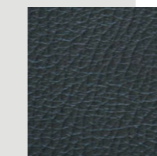

LL | oceano

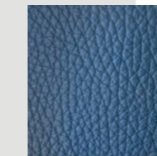

LA | azurblau

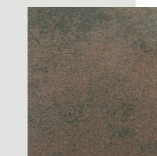

VB | bronze

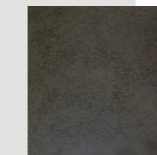

VM | moor

Leder

Leather | Cuir

Kräftiges, weiches Rindleder mit markanter Oberflächenstruktur (Milkorn) und hochwertigen Farbpigmenten.

Strong, soft cowhide leather with distinctive surface structure and high-quality colour pigments.

Cuir de vachette résistant, souple, à la surface remarquable et aux pigments colorés haut de gamme.

Vintage

Vintage | Vintage

Textilleder in used look aus 100% Mikrofaser (PES).

Faux leather in used look made from 100% microfiber (PES).

Cuir synthétique effet usé, 100% microfibrés (PES).



SB | basaltbraun

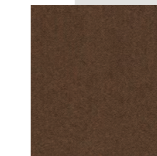

SK | kupfer



SN | natur

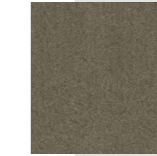

SU | umbra



SH | honiggelb

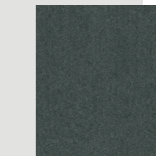

SM | mineralblau

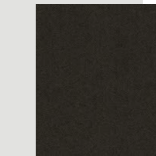

SS | schwarz

Select

Select | Select

Textil mit natürlicher Haptik aus Mischgewebe. (29 % PES, 27 % PAN, 22 % CV, 13 % WO, 9 % CO).

Textile with a natural feel made from blended fabric. (29 % PES, 27 % PAN, 22 % CV, 13 % WO, 9 % CO).

Textile au toucher naturel en tissu mélangé. (29 % PES, 27 % PAN, 22 % CV, 13 % WO, 9 % CO).



Voglauer Qualitätssiegel

Voglauer seal of quality
La qualité Voglauer

Achten Sie auf das Voglauer Label und den Brennstempel – das Qualitätssiegel für originale Voglauer Möbel aus dem Salzburger Land. Hier kaufen Sie höchste Qualität und Natürlichkeit!

The Voglauer label and the branding iron are the hallmark of quality for original Voglauer furniture from Salzburger Land. Here you will purchase premium quality and naturalness!

Les labels Voglauer sont la marque de qualité de meubles originaux provenant du Salzburger Land. Chez Voglauer, vous ne trouverez que des meubles naturels et de qualité supérieure!





Mitarbeiter Transport für weniger CO₂

Holz aus zertifizierter nachhaltiger Forstwirtschaft

IM HERZEN DER NATUR WERDEN NATURHOLZ MÖBEL GEFERTIGT

PV-Anlage + Wasserkraftwerk für Eigenbedarf

Lösungsmittelfreie Oberflächen seit 1990

Thermische Verwertung von Holzabfällen

Modernste Heizungsanlage für weniger CO₂

Im Kreislauf mit der Natur

Als verantwortungsvoller Produzent von Naturholzmöbeln steht die Marke Voglauer seit jeher für einen nachhaltigen Umgang mit den Ressourcen der Natur. Daher werden im Fertigungsprozess ausschließlich Hölzer aus nachhaltiger Forstwirtschaft verwendet, womit Voglauer voll im Kreislauf mit der Natur produziert.

Jeder verwendete Baum, den man sich als Möbel ins Haus holt, wächst mit Garantie wieder nach.

Die Möbel von Vtektura bestehen nicht nur durch formvollendetes Design, sondern auch durch höchste Qualität und Natürlichkeit.

Damit die natürlichen Oberflächen dieser Möbel besonders gut zum Ausdruck kommen, werden sie mit dem einzigartigen Voglauer Oberflächensortiment behandelt. Aus nachwachsenden Rohstoffen hergestellt, schafft diese Hartöl-Wachskombination auf Basis pflanzlicher Öle die perfekten Voraussetzungen für gesundes Wohnen.

In harmony with the natural cycle

As a responsible manufacturer of natural wood furniture, Voglauer has always stood for sustainable use of nature's resources. Therefore, only wood from sustainable forestry is used in the production process, which means that Voglauer produces in total harmony with natural cycles.

Every tree used to make our furniture is guaranteed to grow back.

Vtektura furniture not only impresses with its naturalness, but also with its refined design and its highest quality.

To ensure that the natural surfaces of this furniture are particularly well expressed, they are treated with the unique Voglauer surface range. Made from renewable raw materials, this hard oil-wax combination based on plant oils creates the perfect conditions for a healthy living.

En cycle avec la nature

En tant que fabricant responsable de meubles en bois naturel, Voglauer a toujours mis un point d'honneur à n'utiliser que des matériaux naturels gérés durablement. C'est pourquoi seuls des bois issus de la sylviculture durable sont utilisés dans le processus de fabrication, ce qui permet à Voglauer de produire entièrement en cycle avec la nature.

Chaque arbre utilisé pour fabriquer nos meubles est garanti de repousser.

Les meubles Vtektura ne séduisent pas seulement par leur caractère naturel mais aussi par leur design aux finitions parfaites, et leur qualité supérieure.

Pour que les surfaces naturelles de ces meubles soient particulièrement bien mises en valeur, elles sont traitées avec l'assortiment de produits d'entretien Voglauer. Fabriquée à partir de matières premières renouvelables, cette combinaison d'huile dure et de cire à base d'huiles végétales crée les conditions parfaites pour un habitat sain.

Kommoden | Chests of drawers | Commodes

Dielschränke | Wardrobes | Armoires

Alle Elemente auch spiegelbildlich lieferbar

Spiegel | Mirrors | Miroirs

Elements also available in mirror image
Éléments également disponibles en version inversée

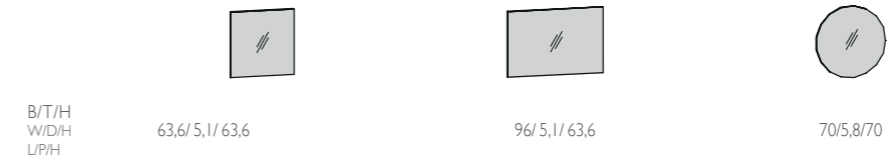
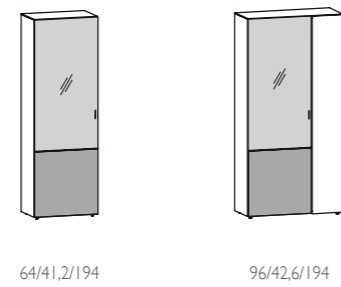
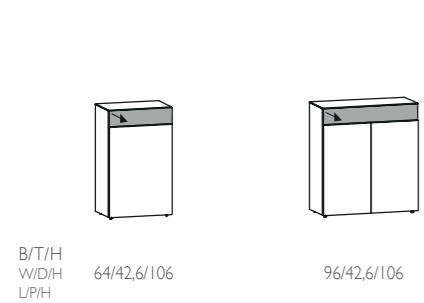

Hängeelemente | Wall-mounted units | Meubles suspendus

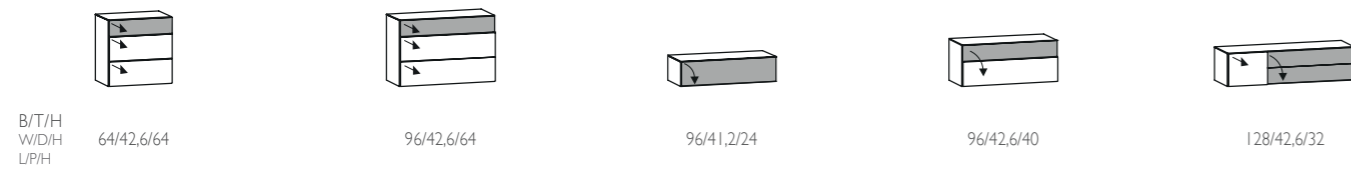

Dielenvorschläge | Wall combinations | Combinaisons murales

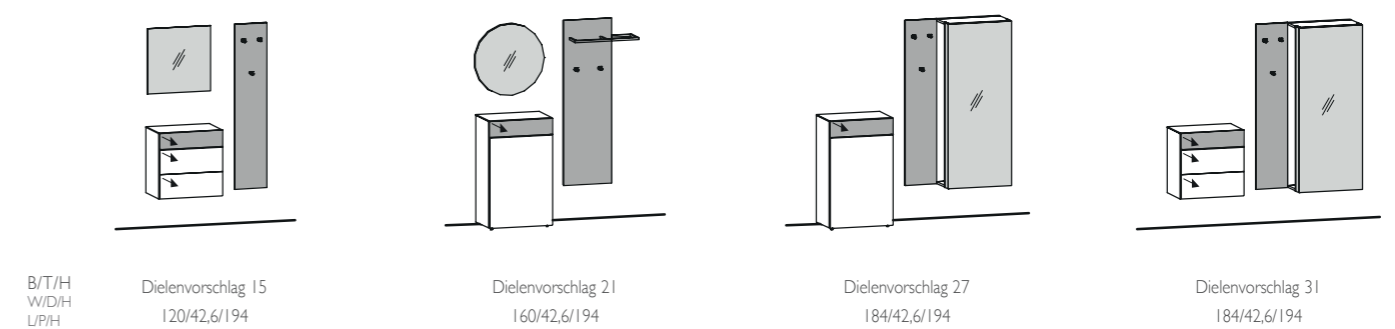

Garderobenelemente | Wardrobes panels | Panneaux de garde-robe

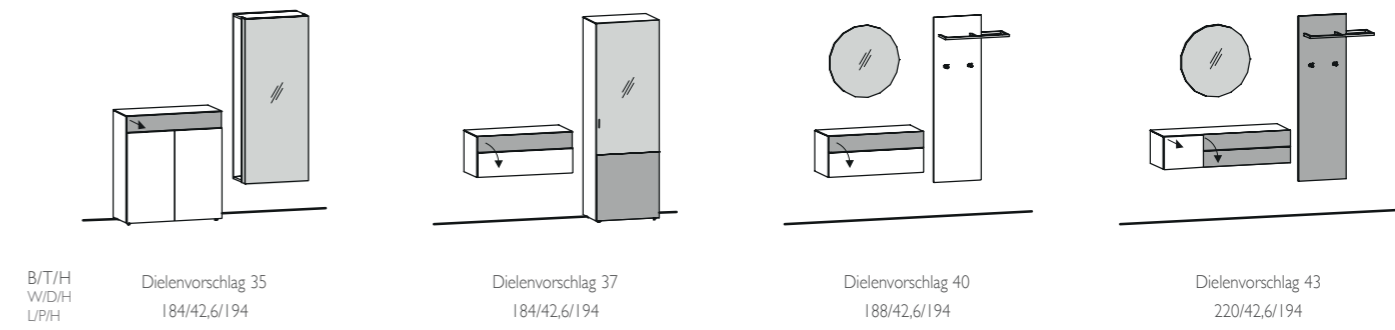
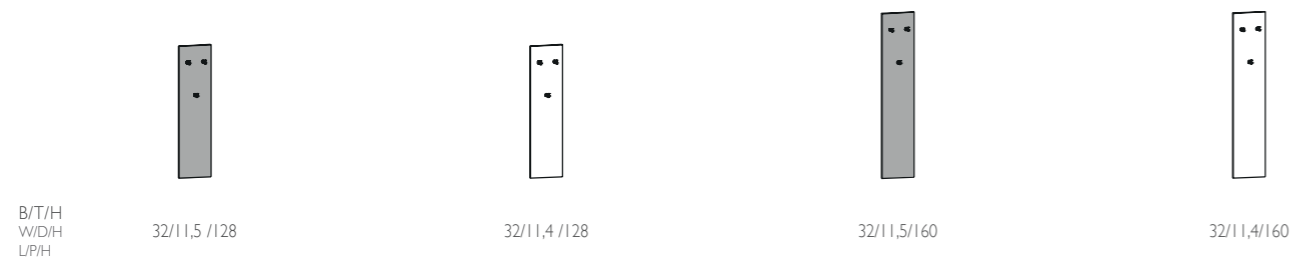

Garderoben | Wardrobes | Garde-robe

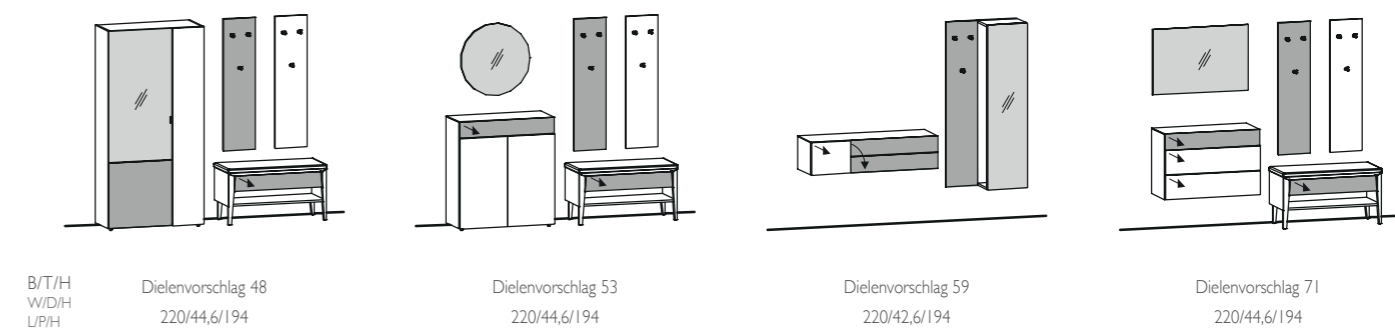
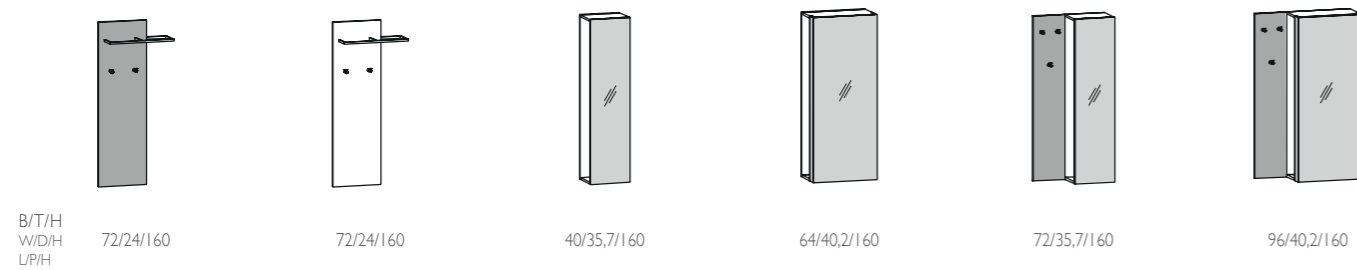

Bänke gepolstert | Upholstered benches | Bancs rembourrés

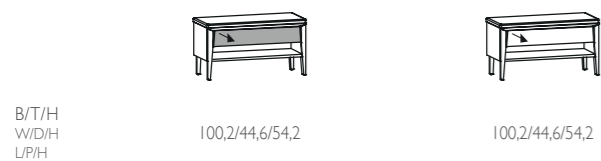

Die komplette Typenliste – alle Varianten und Typen – kann auf unserer Homepage heruntergeladen werden.

The complete type list can be downloaded on our homepage.

La liste complète de modèles peut être téléchargée sur notre site internet.



Weitere Informationen über Typen und Varianten erhalten Sie bei unserem Möbelhandelspartner in Ihrer Nähe! Zu finden im Internet auf www.voglauer.com unter der Rubrik: „Händler“.

For more information about our furniture, please visit our nearest partner! You will find the list of our partners on our website www.voglauer.com, in the "Retailer" section.

Pour plus d'information concernant nos meubles, n'hésitez pas à aller voir notre partenaire le plus proche de chez vous! Vous trouverez la liste de nos partenaires sur notre site www.voglauer.com, dans la rubrique « Revendeurs ».

ALLE VOGLAUER MÖBELLINIEN



Wohnen/Speisen



Valpin



Vmontanara



Vrock living



Vtektura living



Schlafen



Valpin sleeping



Vmontanara sleeping



Vvaganto



Dielen



Valpin



Vmontanara



Vrock coming



Vtektura coming



Bad



Valpin bad



Vmontanara bad



Vquell



Vlineos

Ihr Voglauer Einrichtungspartner:



Möbelgütepasp
Gebrauchs- und Pflegeanweisung



Fordern Sie die gewünschten Folder telefonisch oder auf unserer Homepage an. Wir senden Ihnen diese gerne kostenlos zu.

Sie wollen mehr über unser Unternehmen oder unsere Produktlinien erfahren? Dann besuchen Sie uns im Internet unter www.voglauer.com



Abonnieren Sie uns auf unsere sozialen Medien. Hier werden Sie regelmäßig über aktuelle Entwicklungen und News rund um Voglauer informiert.



Voglauer Gschwandtner & Zwilling GmbH
Pichl 55, A-5441 Abtenau
Tel.: +43 (0) 6243 2700-0
office@voglauer.com | www.voglauer.com

